

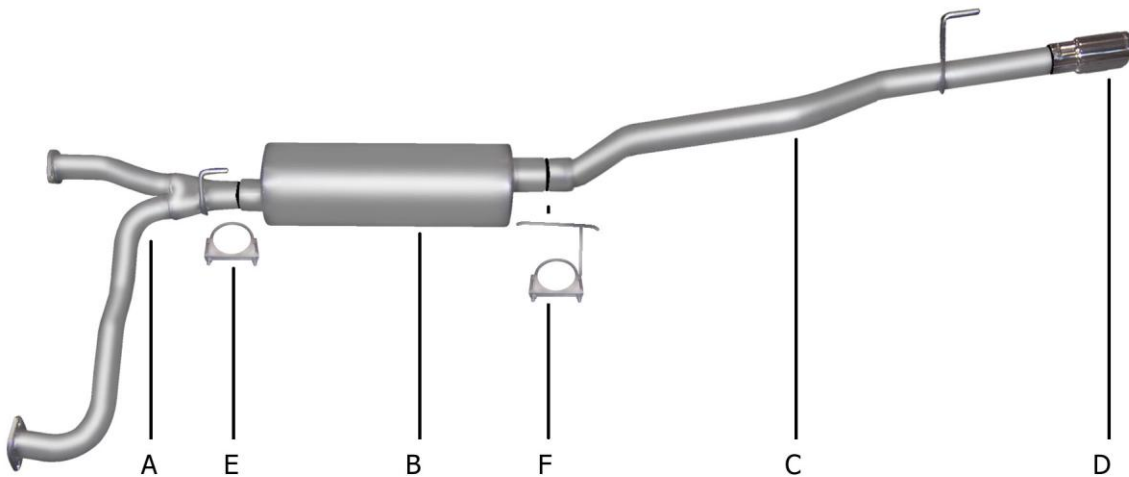

PERFORMANCE EXHAUST SYSTEMS

INSTRUCTION MANUAL
CAT-BACK SINGLE STAINLESS REAR EXHAUST
NISSAN PATHFINDER
4.0L-V6 4WD 4DR
PART # 612210



ITEM	PART #	QTY	DESCRIPTION
A	883-700631S	1	2½" Y-PIPE W/GP-110 FLANGES & HANGER
B	421887	1	STAINLESS SUPERFLOW MUFFLER
C	887-700632S	1	2½" S.S TAILPIPE W/ WELDED HANGER
D	500361	1	3" STAINLESS TIP
E	OHD300	1	3" CLAMP
F	4235	1	2½" REAR MUFFLER HANGER

Thank you for purchasing our GIBSON EXHAUST SYSTEM for your vehicle. If you need further assistance, please do not hesitate to call our Technical Department at (800) 528-3044, Monday through Friday, 8:00 am to 5:00 PM.

EXHAUST INSTALLATION #612210

When installing this exhaust system make sure to use proper safety precautions. Use jack stands when under the truck, set parking brake, block tires and use safety glasses and gloves.

DO NOT WORK WITH HOT PIPES!

SUGGESTED TOOLS:

1/2", 9/16", 14MM & 12MM Socket, WD-40, Jack Stand, Hacksaw



LAY OUT THE GIBSON EXHAUST ON THE FLOOR AND COMPARE PART #'S TO THE DRAWING. TO REMOVE THE STOCK EXHAUST REMOVE IT FROM THE 2 BOLT FLANGES, LOCATED IN FRONT OF YOUR FACTORY MUFFLER. NEXT, CUT OFF YOUR STOCK TAILPIPE BEHIND YOUR MUFFLER.

DO NOT DISCARD YOUR FACTORY HARDWARE, YOU WILL RE-USE IT.



NEXT, INSTALL REAR MUFFLER HANGER # F ONTO OUTLET OF MUFFLER. INSERT HANGER INTO RUBBER GROMMET. DO NOT TIGHTEN.



INSTALL Y-PIPE # A ONTO YOUR EXISTING STOCK FLANGES. INSERT HANGER INTO RUBBER GROMMET. USE YOUR FACTORY HARDWARE TO SECURE. DO NOT TIGHTEN.



INSTALL OVERAXLE TAILPIPE # C INTO MUFFLER 1 1/2"-2". SECURE TO THE MUFFLER USING CLAMP # F. DO NOT TIGHTEN.



INSTALL MUFFLER # B ONTO HEAD PIPE # A 1-1/2" TO 2" WITH THE LOUVERS FACING TOWARDS THE CONVERTER. USE A JACK STAND TO SUPPORT THE MUFFLER. USE CLAMP # E TO SECURE THE MUFFLER TO THE HEAD PIPE. DO NOT TIGHTEN. MUFFLER INLET IS LOOKING INTO THE LOUVERS. OUTLET OF MUFFLER WILL BE AT THE ONE O'CLOCK POSITION.



INSTALL YOUR STAINLESS TIP # D TO YOUR DESIRED LOOK. NOW GO BACK AND TIGHTEN ALL YOUR FLANGES, CLAMPS, ETC. STARTING FROM THE FRONT AND WORKING YOUR WAY BACK. TO CLEAN YOUR STAINLESS TIP USE A STAINLESS CLEANER AND A SCOTCH BRITE PAD.

MAKE SURE YOU HAVE A 1" CLEARANCE ON ALL RUBBER BRAKE LINES, SHOCK BOOTS, TIRES, FUEL LINES, ETC...